

Hynautic inboard steering

Hynautic

premium
inboard steering

HYNAUTIC®
3-LINE DUAL STATION
INBOARD SYSTEM

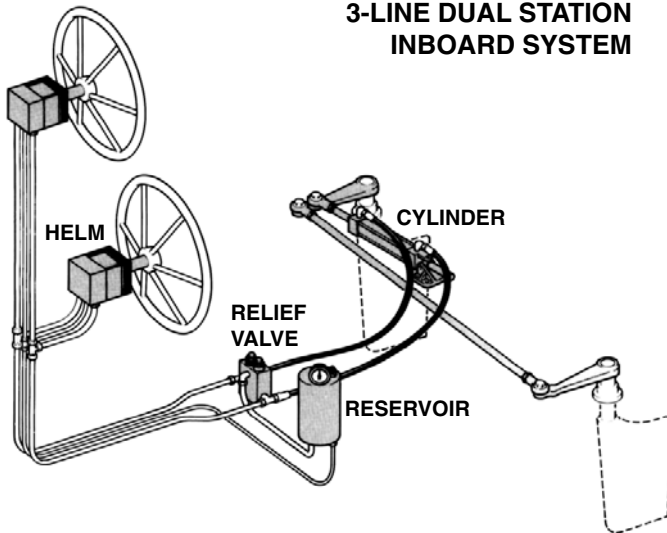

(turns vary by system)

DIMENSIONS: pages 160-168
HOW TO SPEC: page 134
SERVICE PARTS: pages 148-151
SUPPORT: www.teleflexmarine.com
or call 604-270-6899

NOTE: When properly installed, this steering system will connect to inboard engines using appropriate engine/rudder connection hardware.

SeaStar offers rugged 3-line Hynautic Heavy Duty steering systems for most work and pleasure vessels up to 70 feet.

Heavy Duty helms combine one or two bi-directional axial piston pumps with pilot check and make-up check valving. The result is a unit which prevents rudder feedback, is very efficient (even at low RPM), and is immediately adaptable to multi-station use.

A wide choice of helm displacements and cylinder configurations make it easy to spec a system which can handle a variety of large boat performance requirements and accommodate most user preferences.

Features:

- Low friction heavy duty hydraulic steering.
- Helm/cylinder combinations for most inboards. Marine grade materials.
- Heavy duty helms available in three displacements, to accommodate most applications and user preferences.
- Helms available with 1" straight shaft or 3/4" tapered. Mount facing any direction.
- Quick air purge relief valve.
- Fluid fill at remote reservoir.
- Heavy duty brass cylinders. Two-axis articulation. Easy installation for single or dual rudder vessels.
- Meets or exceeds applicable standards.
- Accepts most steering wheels.

How to Spec a System:

1. From the application guide select components appropriate for the vessel based on:
 - a) hull type — displacement or planing;
 - b) length of vessel; and
 - c) number of steering wheel turns desired.
2. Select the fitting and hose kits required, based on type of plumbing (1/2" or 5/8" tubing or hose) and based on number of steering stations.
3. Confirm that there is sufficient space available in the dash and engine compartment(s) for the steering components. See helm and cylinder dimensions at the end of this section.

NOTE: If you have any questions, please contact Teleflex (Canada) Tech Service at www.teleflexmarine.com or FAX us at (604) 270-7172.

hydraulic 3-line inboard steering, boats to 70 feet and up

Components:

Hynautic 2.75 cu. in. helm (1" straight shaft)H-21 or
 Hynautic 2.75 cu. in. helm (3/4" tapered shaft).....H-25 or
 Hynautic 4.0 cu. in. helm (1" straight shaft)H-42 or
 Hynautic 4.0 cu. in. helm (3/4" tapered shaft). H-42-02 or
 Hynautic 5.5 cu. in. helm (1" straight shaft)H-41 or
 Hynautic 5.5 cu. in. helm (3/4" tapered shaft).....H-41-02
(See application guide on next page.)

H-20 Fittings Kit for Main Station.....HF-10
 H-40 Fittings Kit for Main Station.....HF-21
 Inboard CylinderHC53_ or K-_
(See application guide on next page. 1 or 2 required.)

Reservoir - Standard (2 quart)..... R-06
 Relief Valve (950 PSI) MSV-21
 Relief Fittings (1150 & 1175-21-1) MSVF-07
 Relief Fittings (1175-42-1 & up)..... MSVF-13
 Copper Tubing 1/2" or 5/8" OD
(See application guide on next page.)

Fitting Kit (for 1/2" Copper Tubing)HF5590 or
 Fitting Kit (for 5/8" Copper Tubing) HF5592
(See application guide on next page. These fitting kits are for one steering station; purchase add-a-station kit for 2nd station.)

Hose Kit for Copper Tubing (2 hoses)HA5731
Contains two 18" (.45m) hoses for single-cylinder installations.

SeaStar Oil (1 Gallon)HA5440
(Other fittings may be required. Contact Teleflex Canada.)

Options:

Pivot Mount Inboard Cylinder K-31
 Dual Cylinder Hose 2' (.6m)HA5732
 Dual Cylinder Hose 3' (.9m)HA5733
 Dual Cylinder Hose 4' (1.2m)HA5734
 Dual Cylinder Hose 5' (1.5m)HA5735
 Dual Cylinder Hose 6' (1.8m)HA5736
Hoses sold individually (4 required for dual cylinder installations).

Reservoir (2 quart, with hand pump) R-07
 Reservoir (1 quart, with hand pump) R-11
 Reservoir (2 quart)..... R-12
 Relief Valve (500 PSI) MSV-19
 Reservalve (500 PSI, top read, 3/8)RV-55
 Reservalve (500 PSI, top read, 3/8, w/pump) RV-55P
 Reservalve (500 PSI, top read, 5/16, w/pump).RV-57
 Reservalve (950 PSI, top read, 5/16)RV-60
 Reservalve (950 PSI, frt.read, 5/16, w/pump) ..RV-67
 H-20 Fittings Kit for Second StationHF-11
 H-40 Fittings Kit for Second StationHF-22



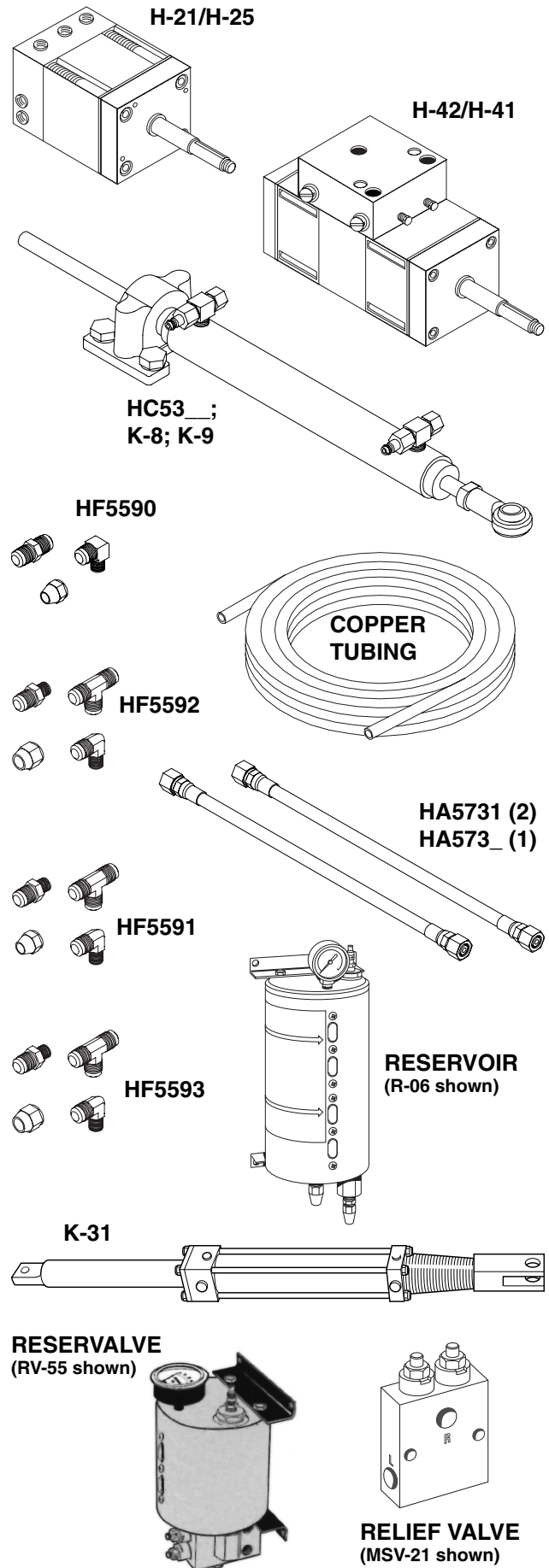

Service Items:

Reservoir (2 quart, with hand pump) R-07
 Reservoir (1 quart, with hand pump) R-11
 Reservoir (2 quart)..... R-12
 Relief Valve (500 PSI) MSV-19
 Reservalve (500 PSI, top read, 3/8)RV-55
 Reservalve (500 PSI, top read, 3/8, w/pump) . RV-55P
 Reservalve (500 PSI, top read, 5/16, w/pump) ..RV-57
 SeaStar Oil (1 Gallon)HA5440



Hynautic inboard steering

Application Guide: 3-Line Inboard Steering

FOR VESSEL SIZES UP TO:	HELM PUMP MODEL	STEERING WHEEL TURNS	REQUIRES CYLINDER MODEL (2x = 2 cylinders)	TUBING DIAMETERS when distance from Cylinder to farthest Helm is:		MAX. SUGG. H.P.	MAX. SUGG. AREA FEET (meters)
				40 Feet or Less	40 Feet or More		
PLANING HULLS: 							
35-50' (11-15m)	H-21 or H-25	5.0	HC5350 or HC5356	1/2"	5/8"	450	—
40-50' (10-18m)	H-21 or H-25	6.8	HC5351 or HC5357	1/2"	5/8"	750	—
40-50' (10-18m)	H-42	4.7	HC5351 or HC5357	1/2"	5/8"	750	—
45-60' (14-18m)	H-42	7.4	HC5378 or HC5379	1/2"	5/8"	950	—
45-60' (14-18m)	H-41	5.4	HC5378 or HC5379	1/2"	5/8"	950	—
55-65' (17-20m)	H-41	5.4	HC5378 or HC5379	1/2"	5/8"	1200	—
to 70' (to 21m)	H-41	10.8	2x HC5378 or HC5379	1/2"	5/8"	1500	—
to 70' (to 21m)	H-41	14.2	2x K-8	1/2"	5/8"	1500	—
DISPLACEMENT HULLS — TUG BOATS, NET HAULERS: 							
to 30' (6-9m)	H-21 or H-25	5.0	HC5350 or HC5356	1/2"	5/8"	200	—
30-35' (6-11m)	H-21 or H-25	6.8	HC5351 or HC5357	1/2"	5/8"	250	—
30-35' (6-11m)	H-42	4.7	HC5351 or HC5357	1/2"	5/8"	250	—
26-40' (8-12m)	H-42	7.4	HC5378 or HC5379	1/2"	5/8"	400	—
26-40' (8-12m)	H-41	5.4	HC5378 or HC5379	1/2"	5/8"	400	—
30-45' (9-14m)	H-41	5.4	HC5378 or HC5379	1/2"	5/8"	450	—
to 50' (to 15m)	H-41	10.8	2x HC5378 or HC5379	1/2"	5/8"	500	—
to 50' (to 15m)	H-41	14.2	2x K-8	1/2"	5/8"	500	—
to 50' (to 15m)	H-41	20.0	2x K-9	1/2"	5/8"	500	—
DISPLACEMENT HULLS — WORK & PLEASURE BOATS: 							
to 40' (9-12m)	H-21 or H-25	5.0	HC5350 or HC5356	1/2"	5/8"	300	—
40-45' (12-14m)	H-21 or H-25	6.8	HC5351 or HC5357	1/2"	5/8"	350	—
40-45' (12-14m)	H-42	4.7	HC5351 or HC5357	1/2"	5/8"	350	—
40-55' (12-17m)	H-42	7.4	HC5378 or HC5379	1/2"	5/8"	500	—
40-55' (12-17m)	H-41	5.4	HC5378 or HC5379	1/2"	5/8"	500	—
45-65' (14-20m)	H-41	5.4	HC5378 or HC5379	1/2"	5/8"	650	—
to 75' (to 23m)	H-41	10.8	2x HC5378 or HC5379	1/2"	5/8"	750	—
to 75' (to 23m)	H-41	14.2	2x K-8	1/2"	5/8"	750	—
SAILBOATS — SKEG RUDDER: 							
to 40' (9-12m)	H-21 or H-25	5.0	HC5350 or HC5356	1/2"	5/8"	—	9 (.9)
40-45' (12-14m)	H-21 or H-25	6.8	HC5351 or HC5357	1/2"	5/8"	—	10 (1)
40-45' (12-14m)	H-42	4.7	HC5351 or HC5357	1/2"	5/8"	—	10 (1)
40-52' (12-16m)	H-42	7.4	HC5378 or HC5379	1/2"	5/8"	—	17 (1.6)
40-52' (12-16m)	H-41	5.4	HC5378 or HC5379	1/2"	5/8"	—	17 (1.6)
50-60' (15-18m)	H-41	5.4	HC5378 or HC5379	1/2"	5/8"	—	18 (1.7)
to 65' (to 20m)	H-41	10.8	2x HC5378 or HC5379	1/2"	5/8"	—	20 (1.9)
to 65' (to 20m)	H-41	14.2	2x K-8	1/2"	5/8"	—	20 (1.9)
SAILBOATS — SPADE RUDDER: 							
to 40' (9-12m)	H-21 or H-25	5.0	HC5350 or HC5356	1/2"	5/8"	—	7 (.6)
40-45' (12-14m)	H-21 or H-25	6.8	HC5351 or HC5357	1/2"	5/8"	—	8 (.7)
40-45' (12-14m)	H-42	4.7	HC5351 or HC5357	1/2"	5/8"	—	8 (.7)
35-46' (11-16m)	H-42	7.4	HC5378 or HC5379	1/2"	5/8"	—	15 (1.4)
35-46' (11-16m)	H-41	5.4	HC5378 or HC5379	1/2"	5/8"	—	15 (1.4)
40-50' (12-15m)	H-41	5.4	HC5378 or HC5379	1/2"	5/8"	—	15.5 (1.4)
to 60' (to 18m)	H-41	10.8	2x HC5378 or HC5379	1/2"	5/8"	—	16.5 (1.5)
to 60' (to 18m)	H-41	14.2	2x K-8	1/2"	5/8"	—	16.5 (1.5)

hydraulic 3-line inboard steering, boats to 70 feet and up

Helm Options

Four helms are offered in 3 displacements, as noted in the chart at right. The H-21 helm has a 1" straight wheel shaft; H-25 has a 3/4" tapered shaft. The H-42 and H-41 helms both have a 1" straight wheel shaft.

HELM PART #	DISPLACEMENT RANGE	RELIEF VALVE SETTING
H-21	2.75 cu. in.	950 PSI (66 BAR)
H-25	2.75 cu. in.	950 PSI (66 BAR)
H-42	4.0 cu. in.	950 PSI (66 BAR)
H-41	5.5 cu. in.	950 PSI (66 BAR)

Tubeing/Hose Options

Use soft refrigeration type copper tubing for optimum performance. For tube-to-cylinder flex hoses, select a hydraulic hose rated for 1000 PSI (70 bar) working pressure, and with a very low volumetric expansion rating.

HELM TYPE	DISTANCE — CYLINDER TO FURTHEST HELM	
	40 Feet or Less	More Than 40 Feet
ALL	1/2" O.D. Copper Tubing	5/8" O.D. Copper Tubing

Cylinder Options

Cylinders are made from brass & stainless steel. Available with stainless rod & ball joint (TMB models) or stainless rod & bronze clevis (TMC models.) Cylinders with ball joints have 2-axis articulation.

The K-31 is an optional pivot mount cylinder which can be used in the systems numbered "8a" and "8b" on the opposite page. With this cylinder, the number of wheel turns becomes 6.4 (using the H-42 helm) or 4.6 (H-41 helm).

PART NO.	DESCRIPTION/MODEL/ROD END CONFIG.
7" STROKE MODELS:	
HC5350	Cylinder BA175-7TMB (rod end ball joint)
HC5356	Cylinder BA175-7TMC (rod end clevis)
HC5351	Cylinder BA200-7TMB (rod end ball joint)
HC5357	Cylinder BA200-7TMC (rod end clevis)
9" STROKE MODEL:	
HC5373*	Cylinder BA175-9TMB (rod end ball joint)
9.5" STROKE MODEL:	
K-8	Hynautic Cylinder, 2.5" bore (rod end ball joint)
11" STROKE MODELS:	
HC5378	Cylinder BA200-11TMB (rod end ball joint)
HC5379	Cylinder BA200-11TMC (rod end clevis)

* HC5373 replaces the Hynautic K-2 cylinder.

The Application Guide at left should be used with discretion.

The chart is only a guide to selecting a steering system. A steering system manufacturer cannot anticipate all the variables in boat-rudder design that affect steering loads. It is the final responsibility of the boat designer/builder to specify maximum expected steering loads.

If the required information is not available, contact our customer service department at 604-279-2202 (www.teleflexmarine.com) with rudder dimensions, vessel size and anticipated maximum vessel speed.

Definitions of terms used in the charts on these pages:

Planing Hull: maximum hull speed normally exceeds 18 knots.

Displacement Hull: maximum hull speed does not normally exceed 18 knots.

Diameters: Copper tubing diameter shown is O.D. Hose diameter shown is I.D.